

# Catalog

1.Safety instructions and waiver of liability.....	2
1.1 Safety Instructions.....	2
1.2 Lianbility Exclusion.....	2
2.Overview.....	3
2.1 Features.....	3
2.2 MPPT technology.....	4
2.3 MPPT—Four Charging Stage.....	5
3.Dimension.....	7
3.1 Structure & Characteristics of MT3075-BT.....	8
3.2 Option Accessories.....	8
3.2.1 Bluetooth Communication.....	9
4.Structure & Characteristics.....	9
4.1 temperature sensor.....	9
5. Installation.....	9
5.1 Installation Notes.....	9
5.2 Mounting Location Requirements.....	10
5.3 Wiring Specifications.....	10
5.4 Connection.....	11
6. Operation.....	12
6.1 Status Description.....	13
6.3 The interface automatically cycles.....	13
6.4 Key function.....	15
7. Parameters setting.....	15
7.1 Low voltage protection.....	16
7.2 Low Voltage reconnect.....	17
7.4 Battery type.....	17
7.5 Load mode.....	18
7.6 Fault indication.....	19
7.7 Protection.....	20
7.8 Maintenance.....	21

**If you need bluetooth wireless software.see other manual.**

**Contact us if you have any question,Our email is**

**[coolper\\_us@163.com](mailto:coolper_us@163.com)**

## 1.Safety instructions and waiver of liability

### 1.1 Safety Instructions

The following symbols are used throughout this manual to indicate potentially dangerous conditions or mark important safety instructions. Please take care when meeting these symbols.



**WARNING:**Indicates a potentially dangerous condition. Use extreme caution when performing this task.



**CAUTION:**Indicates a critical procedure for safe and proper operation of the controller.



**CAUTION:**

1)There are no user serviceable parts inside the controller. Do not disassemble or attempt to repair the controller.

2)Keep children away from batteries and the charge controller.

### 1.2 Liability Exclusion

The manufacturer shall not be liable for damages, especially on the battery, caused by use other than as intended or as mentioned in this manual or if the recommendations of the battery manufacturer are neglected. The manufacturer shall not be liable if there has been service or repair carried out by any unauthorized person, unusual use, wrong installation, or bad system design.

## 2. Overview

### 2.1 Features

Magic series solar controller is based on an advanced maximum power point tracking (MPPT) technology developed, dedicated to the solar system, the controller conversion efficiency up to 98%.

It comes with a number of outstanding features, such as:

1. Innovative Max Power Point Tracking(MPPT) technology, tracking efficiency >99.9%
2. Full digital technology, high charge conversion efficiency up to 98%
3. LCD display design, read operating data and working condition easily.
4. Real-time energy statistics function.
5. 12/24V automatic recognition
6. Liquid,Gel,AGM and Lithium battery for selection
7. External temperature sensor, automatic temperature compensation
8. Built-in temperature sensor, when the temperature exceeds the set value, the charging current will lower down followed by the decrease of temperature, so as to control the controller's temperature rise
9. Four stages charge way: MPPT, boost, equalization, float With current-limiting charging mode, when the power of solar panel is over-sized and charging current exceeds the rated current, the controller will lower the charging power, which enables the system to work under the rated charging current
10. Multiple load control modes: Always on, Dusk to Dawn, Evening, Manual
11. Support Android mobile phone APP,realize wireless monitoring function of solar controller.
- 12.Use high performance,ultra-low power consumption Bluetooth dedicated chip.Adopt Bluetooth 4.2 and BLE technology,communication distance up to 10m.
- 13.Real-time automatic fault alarm.
- 14.Charging and discharging quantities can be counted and displayed by item grouping and month.
15. Perfect EMC & thermal design
16. Full automatic electronic protect function

### 2.2 MPPT technology

#### MPPT profile

The full name of the MPPT is maximum power point tracking. It is an advanced charging way which could detect the real-time power of the solar Module and the maximum point of the I-V curve that make the highest battery charging efficiency.

#### Current Boost

Under most conditions, MPPT technology will "boost" the solar charge current.

MPPT Charging: Power Into the controller (Pmax)=Power out of the controller (Pout)

$$I_{in} \times V_{mp} = I_{out} \times V_{out}$$

\* Assuming 100% efficiency. Actually, the losses in wiring and conversion exist.

Another benefit of MPPT technology is the ability to charge batteries with solar arrays of higher nominal voltages. For example, a 12 Volt battery bank may be charged with a 12-, 24-, nominal off-grid solar array. Grid-tie solar modules may also be used as long as the solar array open circuit voltage (Voc) rating will not exceed the maximum input voltage rating at worst-case (coldest) module temperature. The solar module documentation should provide Voc vs. temperature data.

Higher solar input voltage results in lower solar input current for a given input power. High voltage solar input strings allow for smaller gauge solar wiring. This is especially helpful and economical for systems with long wiring runs between the controller and the solar array.

If the solar module's maximum power voltage (Vmp) is greater than the battery voltage, it follows that the battery current must be proportionally greater than the solar input current so that input and output power are balanced. The greater the difference between the Vmp and battery voltage, the greater the current boost. Current boost can be substantial in systems where the solar array is of a higher nominal voltage than the battery as described in the next section.

### An Advantage Over Traditional Controllers

Traditional controllers connect the solar module directly to the battery when recharging. This requires that the solar module operate in a voltage range that is usually below the module's Vmp. In a 12 Volt system for example, the battery voltage may range from 10.8-15 Vdc, but the module's Vmp is typically around 16 or 17V.

Because traditional controllers do not always operate at the Vmp of the solar array, energy is wasted that could otherwise be used to charge the battery and power system loads. The greater

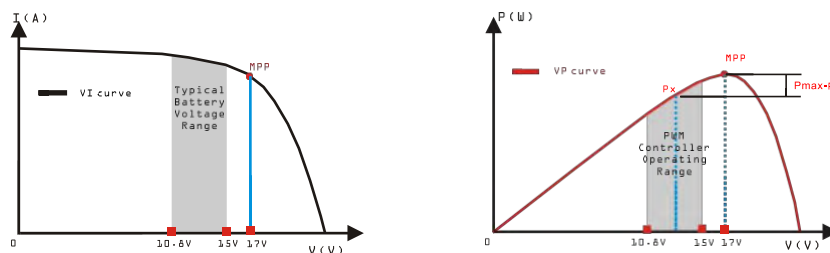

### Nominal 12 Volt Solar Module I-V curve and output power graph.

Contrast with the traditional PWM controller, MPPT controller could play a maximum power of the solar panel so that a larger charging current could be supplied. Generally speaking, the MPPT controller's energy utilization efficiency is 15%~20% higher than PWM controller. 1.3 The dimensions of MT3075

### Conditions That Limit the Effectiveness of MPPT

The Vmp of a solar module decreases as the temperature of the module increases. In very hot weather, the Vmp may be close or even less than battery voltage. In this situation, there will be very little or no MPPT gain compared to traditional controllers. However, systems with modules of higher nominal voltage than the battery bank will always have an array Vmp greater than battery voltage. Additionally, the savings in wiring due to reduced solar current make MPPT

## 2.3 MPPT—Four Charging Stage

Magic series controller has a 4-stage battery charging algorithm for rapid, efficient, and safe battery charging.

**2.3 MPPT—Four Charging Stage**  
Magic series controller has a 4-stage charging.

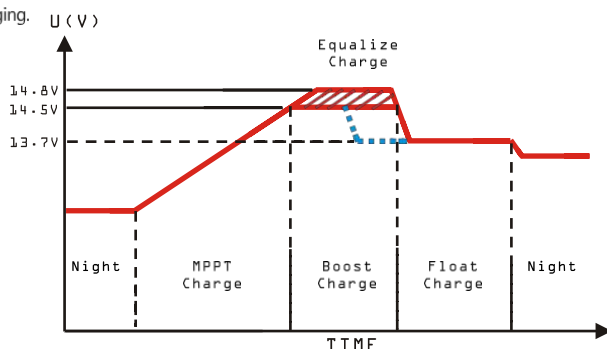

### MPPT Charge

In this stage, the battery voltage has not yet reached boost voltage and 100% of available solar power is used to recharge the battery.

### Boost Charge

When the battery has recharged to the Boost voltage setpoint, constant-voltage regulation is used to prevent heating and excessive battery gassing. The Boost stage remains 120 minutes and then goes to Float Charge. Every time when the controller is powered on, if it detects neither over discharged nor overvoltage, the charging will enter into boost charging stage.

### Float Charge

After the Boost voltage stage, the controller will reduce the battery voltage to Float voltage setpoint. When the battery is fully recharged, there will be no more chemical reactions and all the charge current transmits into heat and gas at this time. Then the controller reduces the voltage to the floating stage, charging with a smaller voltage and current. It will reduce the temperature of battery and prevent the gassing, also charging the battery slightly at the same time. The purpose of Float stage is to offset the power consumption caused by self consumption and small loads in the whole system, while maintaining full battery storage capacity.

In Float stage, loads can continue to draw power from the battery. In the event that the system load(s) exceed the solar charge current, the controller will no longer be able to maintain the battery at the Float setpoint. Should the battery voltage remains below the boost reconnect charging voltage, the controller will exit Float stage and return to Bulk charging.

### Equalize Charge

Certain types of batteries benefit from periodic equalizing charge, which can stir the electrolyte, balance battery voltage and complete chemical reaction. Equalizing charge increases the battery voltage, higher than the standard complement voltage, which gasifies the battery electrolyte. If it detects that the battery is being over discharged, the solar controller will automatically turn the battery to equalization charging stage, and the equalization charging will be 120mins. Equalizing charge and boost charge are not carried out constantly in a full charge process to avoid too much gas precipitation or overheating of battery.



**WARNING: Risk of explosion!**

Equalizing flooded battery can produce explosive gases, so well ventilation of battery box is necessary.

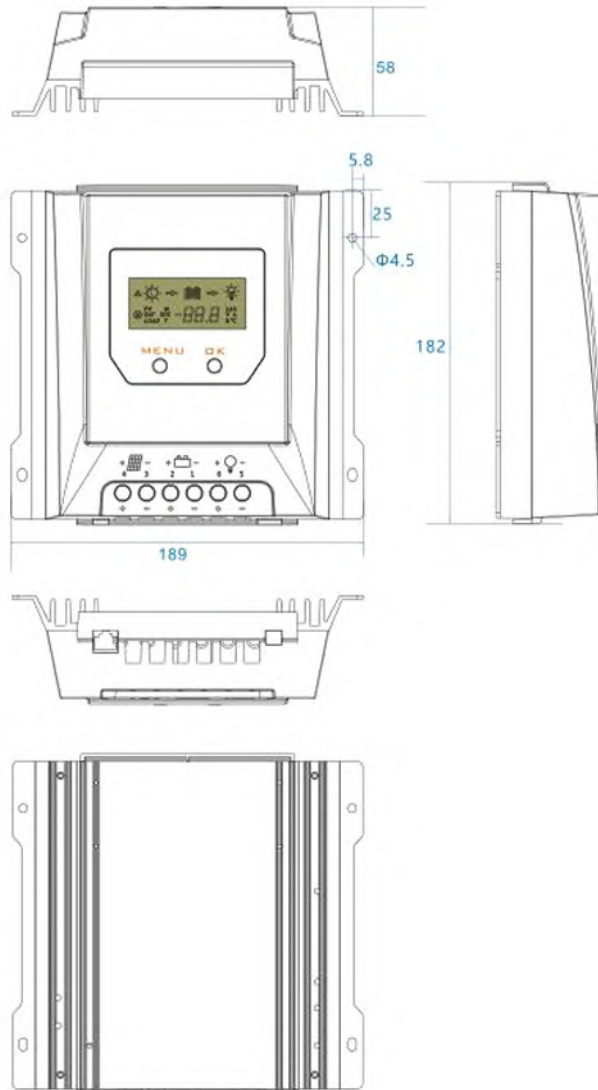

### 3.1 Structure & Characteristics of MT3075-BT

- ① Heat Sink  
--dissipate controller heat
- ② Plastic Case  
--Internal protection
- ③ LCD  
--Display settings and operating status,system parameters
- ④ Key:MENU、OK  
--Set and view the operating parameters
- ⑤ RJ11 interface  
--Connecting monitoring devices
- ⑥ Temperature Sensor Port  
--Collect temperature information,Temperature compensation.
- ⑦ Load Terminals  
--Connected load.

- ⑧ Battery Terminals  
--Connect the battery
- ⑨ Solar module terminals  
--Connected solar modules.

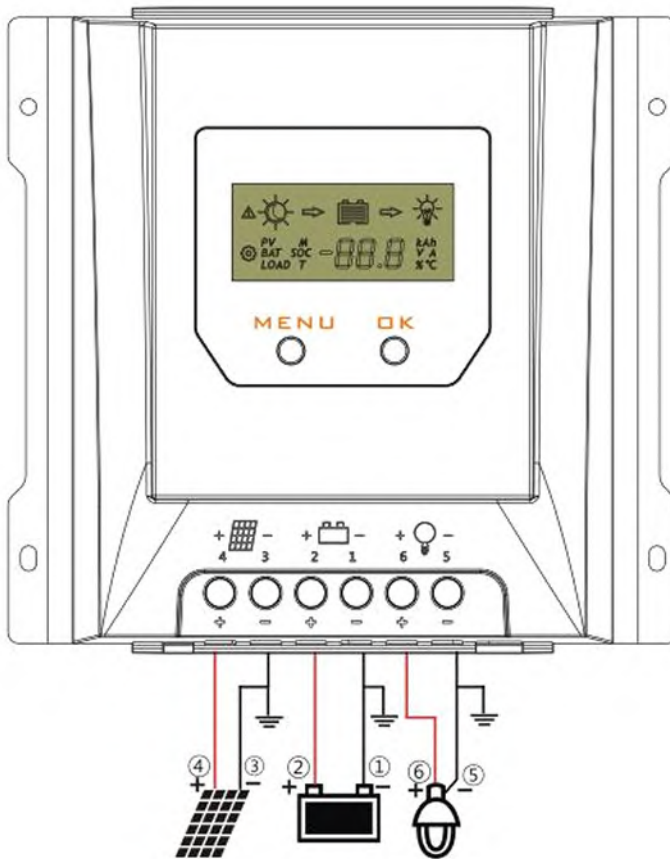

## 3.2 Option Accessories

### 3.2.1 Bluetooth Communication

Bluetooth communication has the following characteristics:

- 1.Support Android mobile phone APP
- 2.Realize wireless monitoring function of solar controller
- 3.Use high performance,ultra-low power consumption Bluetooth dedicated chip.
- 4.Adopt Bluetooth 4.2 and BLE technology.
- 5.communication distance up to 10m



1) This icon in this specification indicates that this BT series solar controller has Bluetooth communication function.

2) Refer to Bluetooth APP instructions for detailed operation of mobile APP .

## 4.Structure & Characteristics

### 4.1 temperature sensor



To collect battery temperature data for temperature compensation so the controller can charge the battery. The temperature sensor connected via interface 6.

If the external temperature sensor is not connected or damaged, the default environment temperature of the controller is 25 °C, and the temperature compensation is not carried out when charging.

## 5. Installation



**CAUTION: Please read all instructions and precautions in the manual before installing!**

It is recommended to remove the acrylic protective film covering the LCD screen before installation.

### 5.1 Installation Notes

1	Connection order: 1)battery 2)panels 3)Load(ensure panels can't get any sunlight when install).The disassembly sequence is contrary to the wiring order . Before wiring installation and adjustment of controller,Always disconnect the solar modules and insurance or circuit breaker of battery terminal.
2	Connect the inverter (DC / AC) to the battery. Do not connect to the solar controller.
3	the load system voltage should be the same as solar system.it means if your solar system is 12V,your load's system voltage must be the 12V.
4	When installing for the first time, please make sure the battery voltage more than 8V so that the Charger controller can recognize system.See recognize range.
5	Make sure the total input voltage under 55V for 12V and 24V and input power is under 390W for 12V system and 780W for 24V system.we suggest the input power more than the half of maximum value.
6	Don't let controller work for long periods with limit maximum Input power or limit max Solar Input voltage or limit max charge current.The max value could find in label of panels.
7	The controller will stop output when the battery under 10.7V(adjustable).
8	The solar charge controller may only be used in PV systems in accordance with this user manual and the specifications of other modules manufacturers.No energy source other than a solar generator may be connected to the solar charge controller.
9	Tighten the wire to ports, otherwise it will produce sparks easily resulting in high temperatures.then burn easily ports.The controller is kept in a cool and breathable place.
10	Batteries store a large amount of energy , never short circuit a battery under all circumstances.We strongly recommend connecting a fuse directly to the battery to protect any short circuit at the battery wiring.
11	Install the Charger controller to the battery as close as possible to avoid voltage and power dropping caused by overlong wire and affect normal voltage judgment.
12	Batteries can produce flammable gases.Avoid making sparks,using fire or any naked flame.Make sure that the battery room is ventilated.
13	Uses insulated tools and avoid placing metal objects near the batteries.
14	Avoid touching or short circuiting wires or terminals.Be aware that the voltages on special terminals or wires can be as much as twice the battery voltage.Use isolated tools,stand on

	dry ground, and keep your hands dry.
15	Dust and weather will affect MPP(MAX Power Point) tracking.make it clean.Sometimes.The data beat because of it tracking the MAX Power Point.
16	Be very careful when working with batteries.Wear eye protection.Have fresh water available to wash and clean any contact with battery acid.
17	Prevent water from entering the internal controller,outdoor installation should avoid direct sunlight and rain penetration.
18	The LCD display has an error of 0.2 V- 0.3 V, but this is normal
19	Do not open the heat sink of the solar controller without permission.

## 5.2 Mounting Location Requirements

Do not mount the solar charge controller outdoors or in wet rooms. Do not subject the solar charge controller to direct sunshine or other sources of heat. Protect the solar charge controller from dirt and moisture. Mount upright on the wall on a non-flammable substrate. Maintain a minimum clearance of 15cm below and around the device to ensure unhindered air circulation. Mount the solar charge controller as close as possible to the batteries.

Mark the position of the solar charge controller fastening holes on the wall, drill 4 holes and insert dowels, fasten the solar charge controller to the wall with the cable openings facing downwards.

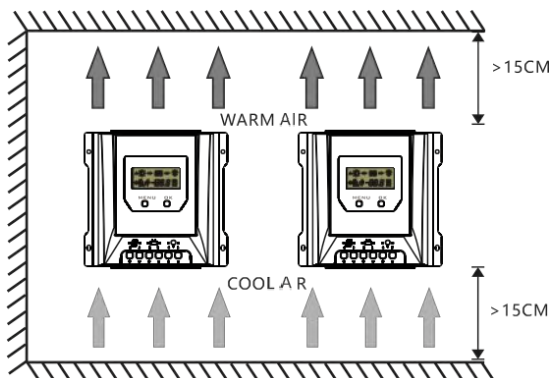

## 5.3 Wiring Specifications

Wiring and installation methods must comply with national and local electrical specifications.

The wiring specifications of the solar, battery and loads must be selected according to rated currents, and see the following table for wiring specifications:

Model	Rated charging current	Rated discharging current	Solar wire diameter (AWG)	Battery wire diameter (AWG)	Load wire diameter (AWG)
MT3075-BT	30A	30A	#4	#4	#4

The wire size is only for reference. If there is a long distance between the PV array and the controller or between the controller and the battery, larger wires can be used to reduce the voltage drop and improve performance.

## 5.4 Connection

We strongly recommend connecting a fuse directly to the battery to protect any short circuit at the battery wiring. Solar PV modules create current whenever light strikes them. The current created varies with the light intensity, but even in the case of low levels of light, full voltage is given by the modules. So, protect the solar modules from incident light during installation. Never touch uninsulated cable ends, use only insulated tools, and make sure that the wire diameter is in accordance with the expected currents of solar charge controller. Connections must always be made in the sequence described below.

Be aware that the negative terminals of controller are connected together and therefore have the same electrical potential. If any grounding is required, always do this on the negative wires.



**WARNING:** Risk of electric shock! Exercise caution when handling solar wiring. The solar PV array can produce open-circuit voltages in excess of 100V when in sunlight. total input power no more than 390W for 12V system and 780W for 24V system, Pay more attention to it.

## CONNECTION DIAGRAM

Warm tip card in package

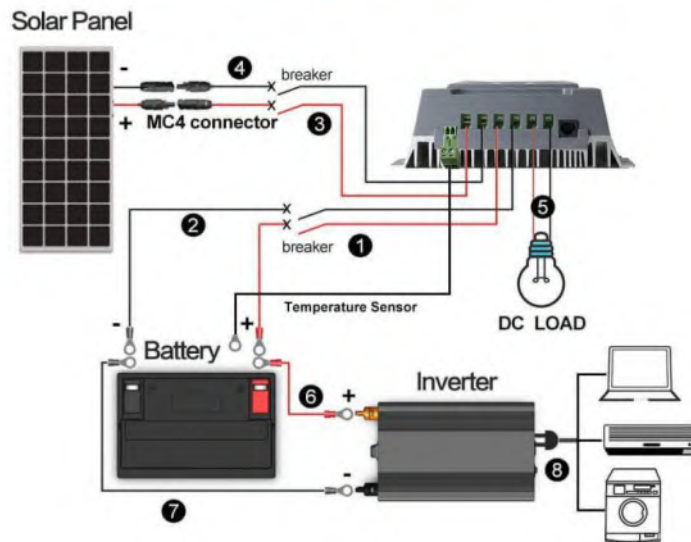

### 1st step: Connect the solar module

Install air circuit breaker between controller and PV modules. Turn off the circuit breaker, and ensure the PV polarity correct, then connect wires between PV modules and controller.

### 2nd step: Connect the battery

Connect the battery connection cable with the correct polarity to the middle pair of terminals on the solar charge controller (with the battery symbol). If the system is 12V, please make sure that the battery voltage is within 10V~15V, else if the system is 24V, the battery voltage should be between 20V~30V, the LCD on the controller will begin to show.

### 3rd step: Connect the solar module

Ensure that the solar module is protected from incident light. Ensure that the solar module does not exceed the maximum permissible input current. Connect the solar module connection cable to the correct polarity of the left pair of terminals on the solar charge controller (with the solar module symbol).

### 4th step: Connect loads

Connect the load cable to the correct polarity of the right pair of terminals on the solar charge controller (with the lamp symbol). To avoid any voltage on the wires, please connect the wire to the load before connect to the controller.

### 5th step: Confirm connection

Tighten all cables connected to the controller and remove all the debris around the controller (leaving a space of approx. 5.9 in).

### 6th step: Turn on the air circuit breaker

Turn on the air circuit breaker between controller and batteries. Turn on the air circuit breaker between controller and PV modules.



**CAUTION:** For common-negative system, such as motorhome, it is recommended to use a common-negative controller; but if in the common-negative system, some common-positive equipment are used, and the positive electrode is grounded, the controller may be damaged.

## 6. Operation

### 6.1 Status Description

Item	Icon	Status
PV array		Daytime, not charging
		Daytime, charging
		Night
	<i>PV</i>	PV voltage、 current and ampere hours
	<i>PV T</i>	The total charge ampere hours of the solar panel
Battery		Battery capacity
		Battery voltage (Programmable Low Voltage Discharge)
	<i>BAT</i>	Battery current
	<i>BAT SOC</i>	Battery state of charge (in %)
		Temperature (Clear Bluetooth Device Password)
		Battery type (Programmable)
		Load voltage (Programmable Low Voltage Reconnect)
Load	<i>LOAD</i>	Load current and ampere hours
	<i>LOAD T</i>	The total discharge ampere hours of the load
		Load mode (Programmable)
		The load is on
		The load is off
Fault		Fault indication. See 7.1.4

PV array charge ampere hours and load ampere hours are off after power failure.

### 6.2 The LCD Display

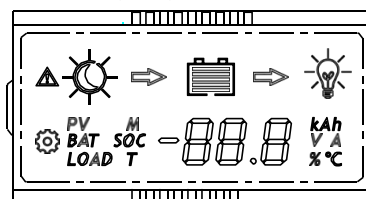

### 6.3 The interface automatically cycles

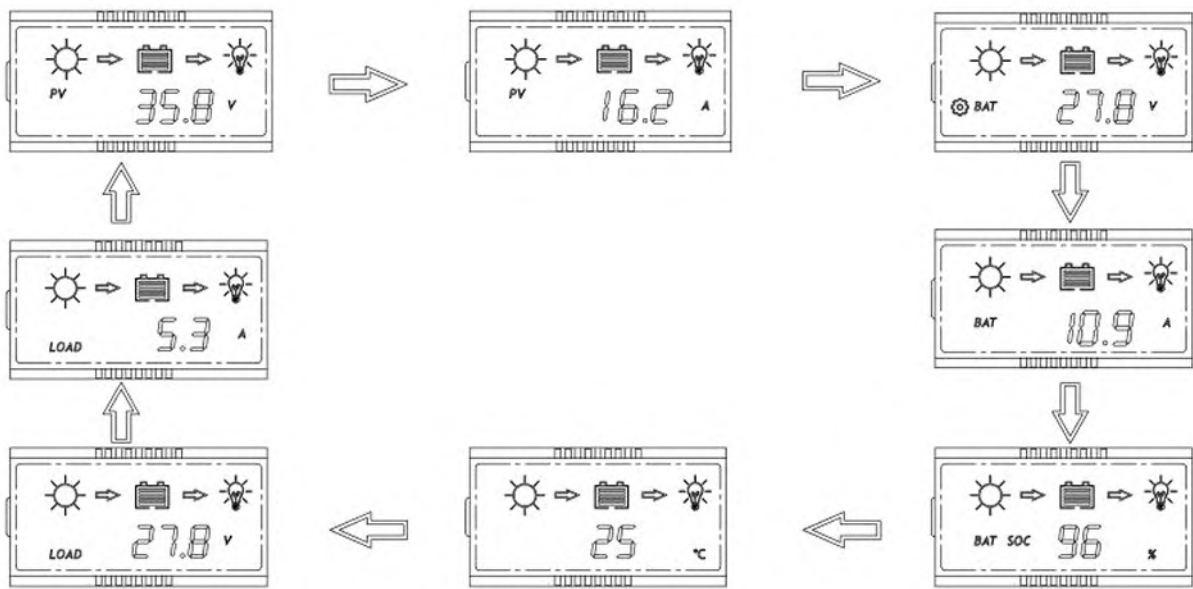

Press OK button to browse the interface

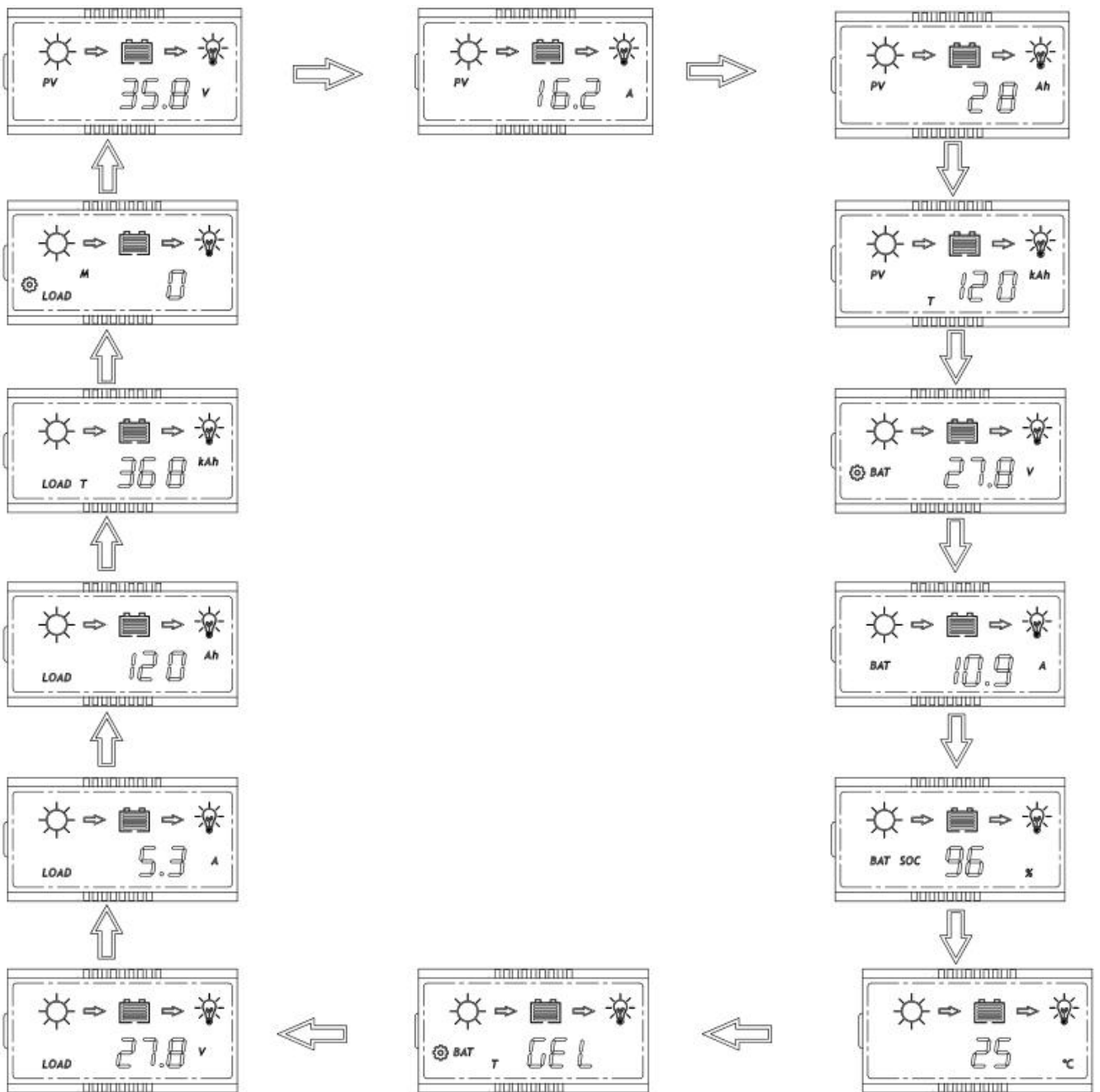

## 6.4 Key function





Mode	Operating
Browse interface	Short press OK
Static display	Press the MENU and OK key at the same time for 1s, the LCD screen will lock the interface. Press the MENU and OK key again for 1s, the LCD interface will unlock and start scrolling.
Setting parameter	Press the MENU key for 1s to enter the setting mode when the icon appears on the display interface, and exit automatically after 30s
Load On/Off	When the controller is working in street lamp mode, press the MENU key for 3s to turn on the load, press the MENU key again or 1min later the load will be off.

## 7. Parameters setting

When the display interface appears icon , means that the current parameters can be set, press the MENU key to start setting, then icon  flashes, press OK to change the parameter.

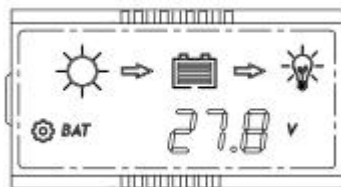
### 7.1 Low voltage protection



When the LCD shows the interface as left, press the **MENU** Key for 1s, the icon  flashes, you can set the controller's low voltage protection.

#### 1. Lithium Battery

When the battery type is lithium battery, the low-voltage protection setting range is 9.0-30.0V (default: 9.0V).

#### 2. Liquid, Gel and AGM Battery

The low voltage protection of the controller can be divided into two types: battery voltage control and capacity control.

##### ① Battery voltage control

Low voltage protection setting range:

10.8~11.8V/21.6~23.6V/43.2~47.2V (default: 11.2/22.4/44.8V).

##### ② Battery capacity control

Display	Low voltage protection
S-1	11.0~11.6V/22.0~23.2V/44.0-46.4V
S-2	11.1~11.7V/22.2~23.4V/44.4-46.8V
S-3	11.2~11.8V/22.4~23.6V/44.8-47.2V
S-4	11.4~11.9V/22.8~23.8V/45.6-47.6V
S-5	11.6~12.0V/23.2~24.0V/46.4-48.0V

## 7.2 Low Voltage reconnect

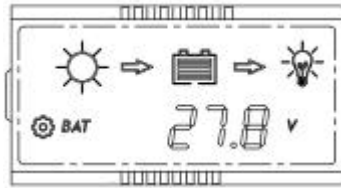

When the LCD shows the interface as left ,press the **MENU** Key for 1s,the icon  flashes,you can set the controller's low voltage reconnect.

### 1. Lithium Battery

When the battery type is lithium battery,the low-voltage reconnect setting range is 9.6-31.0V(default:9.6V).

### 2. Liquid,Gel and AGM Battery

The low voltage reconnect setting range:

11.4~12.8V /22.8~25.6V /45.6~51.2V(default:11.8/23.6/47.2V)



The low voltage recovery voltage(LVR) should be higher than the low voltage protection voltage(LCD) at least 0.6 /1.2 /2.4 V;if you want to improve LVD,you should first improve LVR.



## 7.3 Clear Bluetooth Device Password

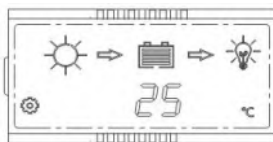



When the LCD shows as the left,press the MENU key for 1s,the icon  flashes,you can press OK to clear the Bluetooth device password set by the mobile app.

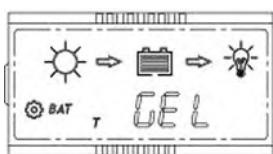

For device passwords,please refer to the Bluetooth APP instructions.

## 7.4 Battery type



When the LCD shows the interface at left ,press the MENU key,the icon  flashes,you can set battery type.

Display	Battery type
GEL	GEL
L I 9	Liquid
AG -	AGM
L I	Lithium



### 1.Charging Volage Parameters(Liquid,GEL,AGM)

When choosing Liquid,GEL or AGM for battery type,the parameters of boost,equalization and float charge voltage can be set by mobile phone APP.The range of parameters is as follows.

The following voltage parameters are 25 °C /12V system parameters,24 /48V system automatically multiplied by 2/4 .



Charging stage	Boost	Equalization	Float
Charging Voltage Range	14.0~15.0V	14.0~15.0V	13.4~14.5V
Default Charging Volage	14.5V	14.8V	13.7V



## 2.Charging Voltage Parameters(Lithium)

When choosing lithium battery type,the overcharge protection and overcharge recovery voltage of lithium battery can be set by mobile phone APP.

Lithium overcharge protection voltage range: 10.0-32.0V(default 12.6V)

Lithium overcharge recovery voltage range: 9.2-31.8V(default 12.4V)

**Note:**  
 (Overcharge Recovery Voltage +1.5V) $\geq$ Lithium Overcharge Protection Voltage  $\geq$ (Overcharge Recovery Voltage+0.2V)



Mobile App does not support parameters beyond this range.

**Warning:** the required accuracy of PVM shall be at least 0.2V.If the deviation is higher than 0.2V,the manufacturer will assume no liability for any system malfunction caused by this.

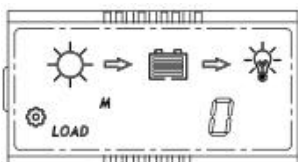
## 7.5 Load mode



When the LCD shows the interface on the left,press the MENU key,the icon  flashes,you can set the load mode.

Display	Load mode
	Always on Mode: The load output is always switched on.
	Dusk to Dawn Mode:The load output is switched on between sunset and sunrise.
23456789	Evening Mode:The load output will be switched on for 2~9 hours after sunset.
USE	Manual Mode:The load output can be switched on and off manually by pressing <b>MENU</b> shortly.

### 1. Always on Mode:

When the controller is set to always On mode,no matter the charging or discharging state,the load always has output(except the protection state).

### 2. Dusk to Dawn or Evening mode:

When the load is set to Dusk to Dawn or Evening mode,the Day/Night threshold voltage and the Day/Night delay time can be set by the mobile phone APP.and the load can be turned on or off by the test function during the day charging process.

## 2.1 Day/Night threshold voltage

The controller recognizes day and night based on the solar array open circuit voltage.

This day/night threshold voltage can be modified according to local light conditions and the solar array used.

Day/Night threshold setting range:3.0~20.0V(lithium,default:8.0V)

Day/Night threshold setting range:3.0~10/6.0~20/12~40V(liquid/Gel/AGM,Default:8/16/32V)

## 2.2 Day/Night delay time

In the evening,when the solar array open circuit voltage reaches the setting day/night detect voltage,you can adjust the day/night delay time to make the load turn on a little later.

Day/Night delay time setting range:0~30 min(default:0 min).

## 2.3 Test Function

When the controller is working in Dusk to Dawn or Evening mode,press the MENU key for 3s to turn on the load .press the MENU key again or the load truns off automatically after 1 minute.

## 3. USE Mode

① If the load mode is selected"USE",you can switch on and off the load output manually by pressing MENU shortly.

 ② The default switching state of the load in manual mode can be changed by mobile APP.



At the same time.the output of the load can be turned on or off.







1. If the controller turns off the load due to low voltage protection.over-current protection.short-circuit protection or over temperature protection..the load will turn on automatically when then controller recovery from protection state.

2. Please note:Pushing the MENU button can still activate the function of the key,even during of the above four kinds protection states.

## 7.6 Fault indication

Faults	Reason	Description	Troubleshooting
 E1	Short circuit	Load off,fault icon display,load icon flashes,the LCD screen displays E1	Switch off all loads, remove short circuit, load will be reconnected after 1 minute automatically
 E2	Over current	Load off,fault icon display,load icon flashes,teh LCD screen display E2	Reduce the load, the controller will resume to work after 1minute.
 E3	Low battery voltage	Battery lever shows empty,fault icon display,battery frame flashes,the LCD screen	Load will be reconnected when battery is recharged

		displays E3	
	Over battery voltage	Battery lever shows full,fault icon display,battery frame flashes,the LCD screen displays E4	Check if other sources overcharge the battery. If not, controller is damaged.
	Over temperature	Turn off the charge and discharge,fault icon display,icon C flashing,the LCD screen displays E5	After the temperature decreases, the controller will work normally
	Communication failure 		Reconnect after disconnecting the battery for about 1 minute and reconnect the Bluetooth device.
	Battery voltage is abnormal at start-up		Charge or discharge the battery so that the battery voltage is within the normal operating range(8.5~15.5V or 20~30V or 40~60V)
Battery can't be charged during daytime	PV panel fault or reverse connection		Check panels and connection wires

## 7.7 Protection

Protection	Description
PV Over Current	The controller will limit charging power in rated charge power.An over-sized PV array will not operate at maximum power point.
PV Short Circuit	When PV short circuit occurs,the controller will stop charging.Remove it to start normal operation.
PV Reverse Polarity	Fully protection against PV reverse polarity,no damage to the controller.Correct the connection to start normal operation.
Battery Reverse Polarity	Fully protection against battery reverse polarity,no damage to the controller.Correct the connection to start normal operation.
Battery Over Voltage	If there are other energy sources to charge the battery,when the battery voltage exceeds 15.8/31.3 /62.3V,the controller will stop charging to protect the battery from overcharging damage.
Battery Over Discharge	When battery voltage drops to the setting voltage point of Low Voltage Disconnect.the controller will stop discharging to protect the battery frm over discharging damage.
Load Over Current Protection	If the load current exceeds the maximum load current rating 1.25 times.the controller will disconnect the load.
Load Short Circuit	Once the load short circuit happens,the load short circuit protection

Protection	will start automatically.
Over Temperature Protection	The controller detects the internal temperature through internal sensor,when the tepearture exceeds the setting value the charging current will lower down followed by the decrease of temperature rise,when the internal temperature exceeds the setting over temperature protection threshold,the controller stops working and restores afterthe temperature is lowered.
Damaged Remote Teamperature Sersor	If the temperature sensor is short-circuited or damaged,the controller will be charging or dicharging at the default temperature 25°C to prevent the battery damaged from overcharging or overdischarged.

## 7.7 Maintenance

The following inspections and maintenance tasks are recommended at least two times per year for best performance.

- ❶ Make sure no block on air-flow around the controller. Clear up any dirt and fragments on radiator.
- ❷ Check all the naked wires to make sure insulation is not damaged. Repair or replace some wires if necessary.
- ❸ Tighten all the terminals. Inspect for loose, broken, or burnt wire connections.
- ❹ Check and confirm that LCD is consistent with required. Pay attention to any troubleshooting or error indication .Take corrective action if necessary.
- ❺ Confirm that all the system components are ground connected tightly and correctly.
- ❻ Confirm that all the terminals have no corrosion, insulation damaged, high temperature or burnt/discolored sign, tighten terminal screws to the suggested torque.
- ❼ Check for dirt, nesting insects and corrosion. If so, clear up in time.

**WARNING:** Risk of electric shock!



Make sure that all the power is turned off before above operations, and then follow the corresponding inspections and operations.

## 8. Technical Data

	Type	MT3075-BT
Battery Parameters	System Voltage	12V/24V automatical recognition
	Max Charging Current	30A
	MPPT Charging Voltage	<14.5/29.0V@25℃
	Boost Voltage	14.0~14.8V /28.0~29.0V @25℃(default:14.5/29V)
	Equalization voltage	14.0~15.0V/28.0~30.0V @25℃(default:14.8/29.6V)
	Float Voltage	13.0~14.5V/26.0~29.0V @25℃(default:13.7/27.4V)
	Low Volt. Disconnect	10.8~11.8V/21.6~23.6V,SOC1~5(default:11.2/22.4V)
	Low voltage reconnect	11.4~12.8V/22.8~25.6V (default:12.0/24.0V)
	Overcharge Protect	15.8/31.3V
	Max volt on Bat. terminal	35V
	Temp. Compensation	-4.17mV/K per cell (Boost, Equal), -3.33mV/K per cell (Float)
	Charging target voltage	10.0~32.0V ( Lithium,default:12.6V)
	Charging recovery voltage	9.2~31.8V (Lithium,default:12.4V)
	Low voltage disconnect	9.0~30.0V (Lithium,default:9.0V)
Battery Type	Flooded, Gel, AGM=sealed,Lithium (default: Gel)	
Panel Parameters	Max volt on PV terminal	55V (-20℃), 50V (25℃)
	Max input power	390W(12V system) / 780W(24V system)
	Day/Night threshold	3.0~20.0V (default : 8.0/16.0V )
	Day/Night delay time	0~30 min (default: 0 min)
	MPPT tracking range	( Battery Voltage + 1.0V ) ~ Voc*0.9
Load	Output Current	30A
	Load mode	Always on, Dusk to Dawn, Evening, Manual
System Parameters	Grounding	Common Negative
	Power terminals	#4 AWG
	Max tracking efficiency	>99.9%
	Max charge conversion	98.00%

	Max tracking efficiency	>99.9%
	Max charge conversion	98.00%
	Dimensions(mm)	189*182*64
	Weight	1kg
	Self consumption	<=13mA
	Ambient temperature	-20 ~ +55 °C
	Storage temperature	-25 ~ +80 °C
	Ambient humidity	0 ~ 100%RH
	Protection degree	IP32
	Max Altitude	4000m

\*1.This value represents the maximum voltage of the solar panel at the minimum operating ambient temperature.

\*2.Voc means the open circuit voltage of the solar panel.

\*3.Around oblique line value separately on behalf of 12V and 24V system's value.

## 9. Parameter table

Contact us if you have any question.our email is [coolper\\_us@163.com](mailto:coolper_us@163.com)

If you have any question,you could tell us your parameters in the following format

parts		parameter
Panels	quantity	
	Per VOC	
	Per power	
	Series or Parallel Connection	
Battery	Battery type	
	per Voltage	
	quantity	
	Series or Parallel Connection	
	Per capacity	
Inverter	input voltage	
	power	
	output voltage	
	Connection placement	
Load	Which product	
	Rated voltage	
	power	
	AC or DC	
	Connection position	
	Continuous rainy days	
	Working hours everyday	
Problem description		